

## Bourdon tube pressure gauge, copper alloy Standard version Models 111.10, 111.12



for further approvals  
see page 3

### Applications

- For gaseous and liquid media that are not highly viscous or crystallising and will not attack copper alloy parts
- Pneumatics
- Heating and air-conditioning technology
- Medical engineering

### Special features

- Reliable and cost-effective
- Design per EN 837-1
- Nominal size 40, 50, 63, 80, 100 and 160
- Scale ranges up to 0 ... 400 bar



**Fig. left: Model 111.12, back mount**

**Fig. right: Model 111.10, lower mount (radial)**

### Description

The model 111 pressure gauges are based on the proven Bourdon tube measuring system. On pressurisation, the deflection of the Bourdon tube, proportional to the incident pressure, is transmitted to the movement via a link and indicated.

The modular design enables a multitude of combinations of case materials, process connections, nominal sizes and scale ranges. Due to this high variance, the instrument is suitable for use in a wide range of applications within industry.

For mounting in control panels, the pressure gauges can, depending on the process connection, be fitted with a surface mounting flange or with a triangular bezel and mounting bracket.

The standard version of the model 111 is manufactured, cost-optimised on modern production lines, in volumes of several million instruments per year.

## Specifications

### Design

EN 837-1

### Nominal size in mm

40, 50, 63, 80, 100

160 only with model 111.10

### Accuracy class

2.5

### Scale ranges

0 ... 0.6 to 0 ... 400 bar (NS 160: max. 40 bar)

or all other equivalent vacuum or combined pressure and vacuum ranges

### Pressure limitation

Steady: 3/4 x full scale value

Fluctuating: 2/3 x full scale value

Short time: Full scale value

### Permissible temperature

Ambient: -20 ... +60 °C

Medium: +60 °C maximum

### Temperature effect

When the temperature of the measuring system deviates from the reference temperature (+20 °C): max.  $\pm 0.4 \text{ \%}/10 \text{ K}$  of the span

### Process connection

Copper alloy

For process connections and spanner widths see page 4

### Pressure element

Copper alloy

C-type or helical type

### Movement

Copper alloy

### Dial

NS 40, 50, 63: Plastic, white, with pointer stop pin

NS 80, 100, 160: Aluminium, white, with pointer stop pin

Black lettering, red mark pointer with measuring ranges

0 ... 0.6 to 0 ... 60 bar

### Pointer

Plastic, black

NS 160: Aluminium, black

### Case

Plastic, black

Model 111.12, NS 100: Steel, black

Model 111.10, NS 160: Steel, black

### Window

Plastic, crystal-clear, snap-fitted in case

Model 111.10, NS 160: Instrument glass

## Options

- Other process connection
- Accuracy class 1.6
- Steel case, black
- Model 111.10: Surface mounting flange (not with NS 40 and 50)
- Model 111.12: Triangular bezel with mounting bracket

## Special versions

### For closed heating systems

NS 63, 80

with red mark pointer and adjustable green sector, scale ranges 0 ... 4 bar, red mark at 2.5 or 3 bar

### For refrigeration plants

NS 63, 80

with additional temperature scale in °C for refrigerants

### For water-level indication (hydrometer) and heating systems







NS 80, 100, 160

Scale ranges 0 ... 0.6 to 0 ... 25 bar, with second scale in mWS and red mark pointer

### For drinking water installations

Material suitability of the wetted parts in accordance with the evaluation criteria for metallic substances of the German federal environmental agency and the "4MS Common Composition List".

**Approvals**

| Logo  | Description   | Country                     |
|---|---|-----------------------------|
|  | <b>EU declaration of conformity</b><br>Pressure equipment directive | European Union              |
|  | <b>EAC (option)</b><br>Pressure equipment directive                 | Eurasian Economic Community |
|  | <b>GOST (option)</b><br>Metrology, measurement technology           | Russia                      |
|  | <b>KazInMetr (option)</b><br>Metrology, measurement technology      | Kazakhstan                  |
| -   | <b>MTSCHS (option)</b><br>Permission for commissioning              | Kazakhstan                  |
|  | <b>BelGIM (option)</b><br>Metrology, measurement technology         | Belarus                     |
|  | <b>UkrSEPRO (option)</b><br>Metrology, measurement technology       | Ukraine                     |
| -   | <b>CPA</b><br>Metrology, measurement technology                     | China                       |
| -   | <b>CRN</b><br>Safety (e.g. electr. safety, overpressure, ...)       | Canada                      |

**Certificates (option)**

- 2.2 test report per EN 10204 (e.g. state-of-the-art manufacturing, material proof, indication accuracy)
- 3.1 inspection certificate per EN 10204 (e.g. indication accuracy)

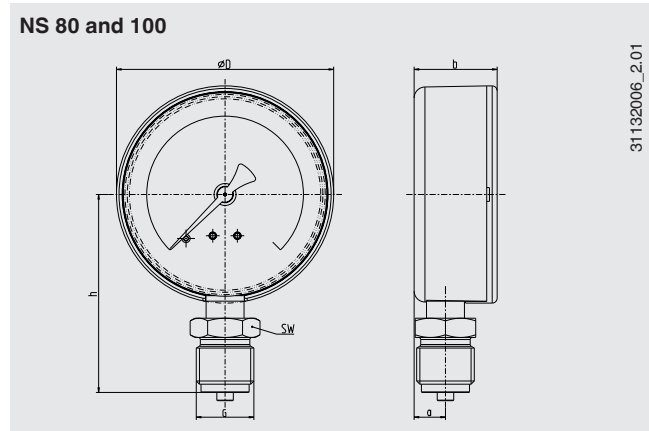
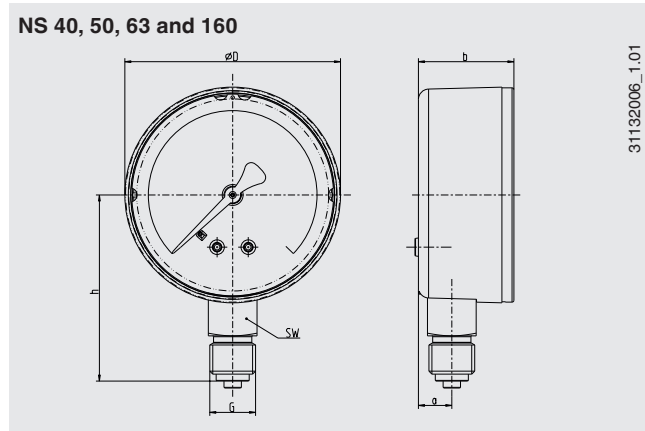
**Dimensions in mm**
**Model 111.10, lower mount (radial)**

| NS  | Dimensions in mm |             |     |         |           |    | Weight in kg |
|-----|------------------|-------------|-----|---------|-----------|----|--------------|
|     | a                | b $\pm 0.5$ | D   | G       | h $\pm 1$ | SW |              |
| 40  | 9.5              | 26          | 39  | G 1/8 B | 36        | 14 | 0.08         |
| 50  | 10               | 27.5        | 49  | G 1/4 B | 45        | 14 | 0.10         |
| 63  | 9.5              | 27.5        | 62  | G 1/4 B | 53.5      | 14 | 0.13         |
| 80  | 11.5             | 30          | 79  | G 1/2 B | 72        | 22 | 0.18         |
| 100 | 11.5             | 30.5        | 99  | G 1/2 B | 83.5      | 22 | 0.21         |
| 160 | 15.5             | 42          | 160 | G 1/2 B | 115.5     | 22 | 0.85         |

Process connection per EN 837-1 / 7.3

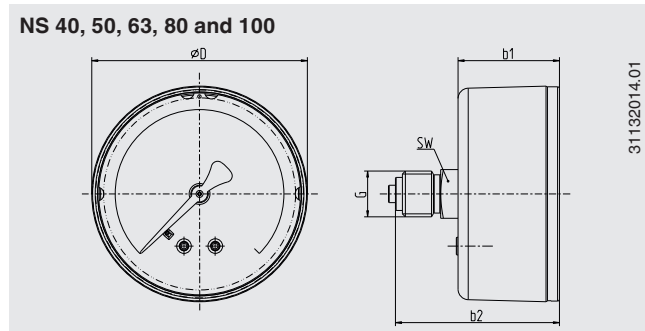
**Model 111.12, back mount**

| NS  | Dimensions in mm |            |    |         |    | Weight in kg |
|-----|------------------|------------|----|---------|----|--------------|
|     | b1 $\pm 0.5$     | b2 $\pm 1$ | D  | G       | SW |              |
| 40  | 26               | 42         | 39 | G 1/8 B | 14 | 0.06         |
| 50  | 29.5             | 47.5       | 49 | G 1/4 B | 14 | 0.07         |
| 63  | 29               | 47         | 62 | G 1/4 B | 14 | 0.08         |
| 80  | 32               | 49         | 79 | G 1/4 B | 14 | 0.11         |
| 100 | 31               | 49         | 99 | G 1/4 B | 14 | 0.26         |

Process connection per EN 837-1 / 7.3